

Fitting Instruction

components

- A : Stopper 1pc
- B : Fixing Screw for Floor Mount Unit 3pcs
- C : Floor Mount Unit 1pc
- D : Allen Key 1pc
- E : Allen Screw 1pc
- F : Spacer 1pc
- G : Door Mount Unit 1pc
- H : Fixing Screw for Door Mount Unit 2pcs

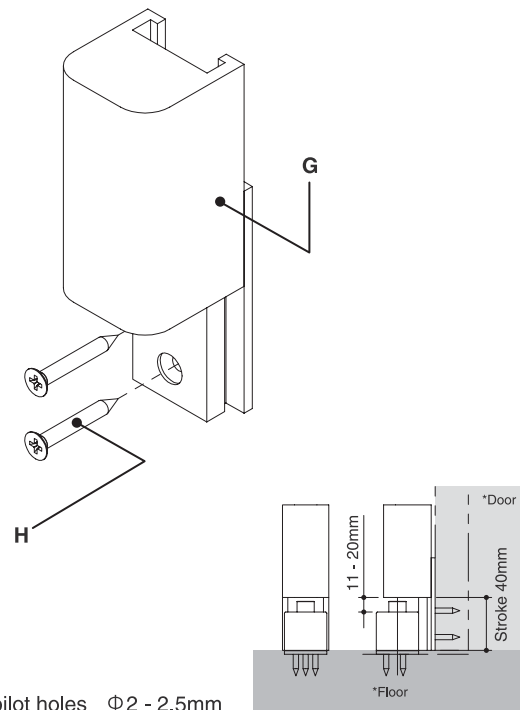
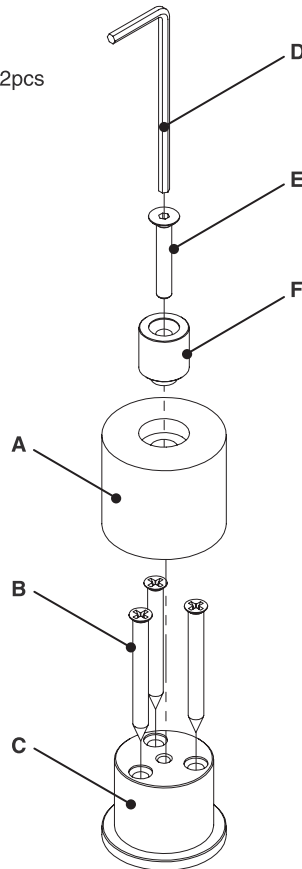

⚠ Attention

This product is suitable only for a wooden door and not suitable for a glass door or a steel door. Make sure to install the product to the place where all the screws hold tightly. If the provided screws are not suitable to the floor, please arrange anchor bolts etc.

Fix the door properly at first and install the floor mount unit after checking the installation position with the door opened. And then, install the door mount unit to where it fits to the floor mount unit perfectly.

Notes

- 1 Please read this instruction well and be sure to install the product correctly. After installation, user shall keep this instruction.
- 2 Please pay attention, not to drop and not to damage the product by fixing tools and etc. while installing.
- 3 Check the installation position before drilling the fixing face.
- 4 Do not use impact drill because it may become hard to remove.
- 5 Do not remodel the product. Do not use the parts except we specify.
- 6 Do not use for a purpose other than the intended use of the product.
- 7 After installation, please confirm whether the product was correctly installed and tightly fixed.
- 8 Avoid installing the product where directly wet with water.

Maintenance

- 1 Check the product regularly and tighten the screw again if it was loose.
- 2 Wipe with soft and dry cloth to clean products.
To remove tough stains use water with soft cloth or sponge, and then wipe enough to dry up.

Regular Cleaning	To remove tough stain	DO NOT USE
Wipe with soft & dry cloth. 	Use water to remove tough stain. Then, dry surface with soft cloth.	